



DOUBLE FLIP WAFFLE MAKER

Select Brands, Inc. Lenexa, KS 66219

MIC-62

IMPORTANT SAFEGUARDS

When using electrical appliances especially when children are present, basic safety precautions should always be followed to reduce the risk of fire, electric shock, and/or injury to persons, including the following:

1. READ ALL INSTRUCTIONS.
2. Do not touch hot surfaces. Metal parts will become hot. Use any handles or knobs.
3. To protect against electrical shock, do not place cord, plug or appliance in water or other liquid.
4. Close supervision is necessary when any appliance is used by or near children.
5. Unplug from outlet when not in use and before cleaning. Allow to cool completely before moving, putting on or taking off parts, or before cleaning.
6. Do not operate any appliance with a damaged cord or plug, or after the appliance malfunctions or has been damaged in any manner. Return appliance to the nearest authorized service facility for examination, repair or adjustment.
7. The use of accessory attachments not recommended by the appliance manufacturer may cause injury.
8. Do not use outdoors.
9. Do not let cord hang over edge of table or counter or touch hot surfaces.
10. Do not place on or near a hot gas or electric burner, or in a heated oven.
11. To disconnect, turn temperature control to lowest setting and unplug from wall outlet. Never pull on the power cord to disconnect.
12. Extreme caution must be used when moving an appliance containing hot oil, water or other hot liquids.
13. Do not use appliance for other than intended use.
14. Do not operate while unattended.

SAVE THESE INSTRUCTIONS

WAFFLE MAKER FEATURES

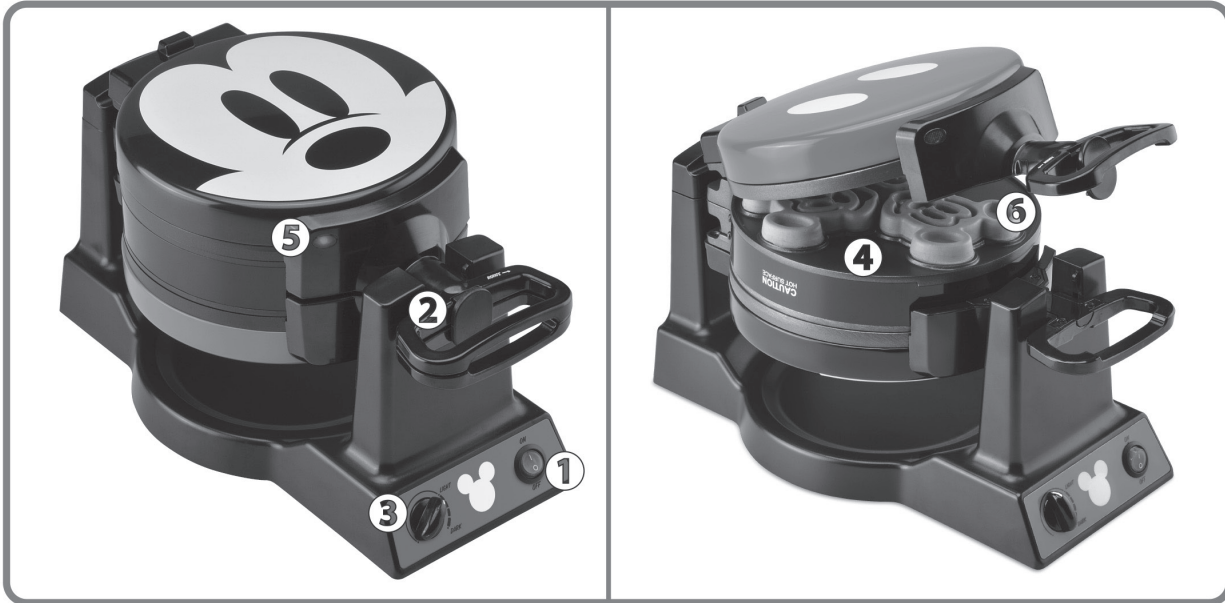

1 Illuminated Power Light

2 Latching Handle

3 Adjustable Heat Control

4 Non-Stick Cooking Surface

5 Ready Indicator Light

6 Character Waffles

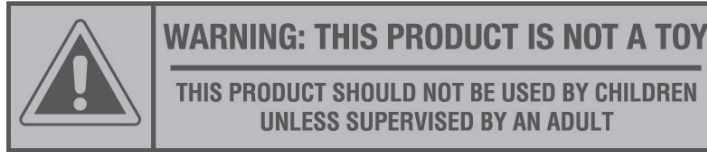

This appliance is for HOUSEHOLD USE ONLY. It may be plugged into an AC electrical outlet (ordinary household current). Do not use any other electrical outlet.

DO NOT OPERATE APPLIANCE IF THE LINE CORD SHOWS ANY DAMAGE, OR IF APPLIANCE WORKS INTERMITTENTLY OR STOPS WORKING ENTIRELY.

A short power-supply cord is to be provided to reduce the risk resulting from becoming entangled in or tripping over a longer cord. Longer extension cords are available and may be used if care is exercised in their use. If an extension cord is used,

1. The marked electrical rating of the extension cord should be at least as great as the electrical rating of the appliance, and
2. The cord should be arranged so that it will not drape over the countertop or tabletop where it can be pulled on by children or tripped over unintentionally.

POLARIZED PLUG

This appliance has a polarized plug (one blade is wider than the other). To reduce the risk of electric shock, this plug is intended to fit into a polarized outlet only one way. If the plug does not fit fully into the outlet, reverse the plug and try again. If it still does not fit, contact a qualified electrician. Do not attempt to modify the plug in any way.

LINE CORD SAFETY TIPS

1. Never pull or yank on cord or the appliance.
2. To insert plug, grasp it firmly and guide it into outlet.
3. To disconnect appliance, grasp plug and remove it from outlet.
4. Before each use, inspect the line cord for cuts and/or abrasion marks. If any are found, this indicates that the appliance should be serviced and the line cord replaced.
5. Never wrap the cord tightly around the appliance, as this could place undo stress on the cord where it enters the appliance and cause it to fray and break.

IMPORTANT

During the first few minutes of initial use, you may notice smoke and/or a slight odor. This is normal and should quickly disappear. It will not recur after appliance has been used a few more times.

For your safety, always read and **follow** the Use and Care Manual before attempting to use any electric appliance.

BEFORE USING:

1. Carefully unpack the waffle maker. Remove all packaging materials, including those which may be inside the product.
2. Wipe exterior surfaces with a soft, damp cloth to remove dust particles collected during packing and handling. Dry thoroughly. Do not use abrasive cleaners. Clean the interior with a warm, soapy cloth. Rinse with a clean, damp cloth and dry thoroughly. **NEVER IMMERSE THE PRODUCT, CORD OR PLUG IN WATER OR ANY OTHER LIQUID.**

Solid surface countertops can be easily scratched, cracked, scorched, or damaged, especially when exposed to heat. To prevent possible damage, consider using a trivet under this appliance.

OPERATING INSTRUCTIONS

1. Place the waffle maker on a flat, level, heat-resistant surface.
2. Plug the power cord into a 120V AC electrical outlet. This appliance should always be operated on a separate 120V ~ 60 Hz wall outlet to ensure that the electrical circuit is not overloaded.
3. Set the power switch to the ON position. The power switch will illuminate and the ready indicator lights will blink once.
4. Turn the browning control dial to the desired setting between LIGHT and DARK. The appliance will heat to the operating temperature of the selected browning level. Once the operating temperature has been reached, the appliance will beep 6 times and the ready indicator lights will turn on. The heating time is approximately 3-5 minutes depending on ingredients. **CAUTION: Do not touch the waffle plates or any metal surfaces. Surfaces are hot.**
5. Unlock the latch by pulling it towards you and lift the lid by the handle to the fully opened position. If desired, apply a coating of cooking spray or oil on the waffle plates. **NOTE: Latch must be in unlocked position to open lid.**



Latch in Locked Position

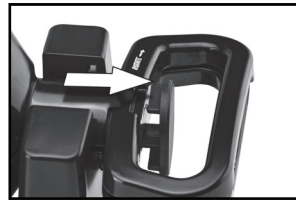

Latch in Unlocked Position

6. Using a measuring cup, start by pouring batter at the center of each character icon reservoir in the lower waffle plate and allow it to evenly spread outward. Do not overfill as any excess batter may leak from the sides of the waffle plates.
7. Close the lid by the handle and lock the latch by pushing it towards the appliance. Make sure the waffle plates cannot be opened.
8. Rotate the handle and waffle plates clockwise 180°. The ready indicator light will turn off while the unit starts baking the waffles of the top plate.

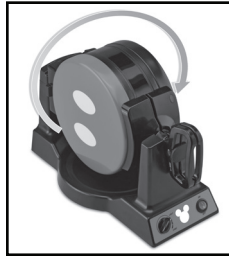

9. In order to cook more waffles using the bottom plate, unlock the latch and lift the red lower lid upward by the handle. Follow step #6 for the waffles of the bottom plate.
10. Close the lid and lock the latch again by pushing it toward the appliance. Make sure neither of the waffle plates can be opened.
11. Rotate the handle and waffle plates counter-clockwise 180° to place the lower lid at the original position. The ready indicator light will turn off while the waffle of the bottom plate is baking.

NOTE: During the cooking process, both ready indicator lights will remain off. Waffles take approximately 3-5 minutes, depending on the recipe or browning preference. As a general rule, when no steam is emitted between the waffle plates, then the waffle is fully cooked.

12. When waffles are finished, the ready indicator light will illuminate and the appliance will beep 3 times.
13. Carefully lift the lid by the handle and remove the waffles using a heat resistant plastic or wooden utensil. Never use metal utensils, as these will damage the nonstick coating. Use CAUTION when handling the waffles, as they will be HOT. Allow waffles to cool for a few minutes before enjoying.
14. Once the waffles of the bottom plate are finished, lower the lid by the handle, engage the lock, rotate the plates 180°, lift the plate by the handle and remove the waffles from the other side.
15. After removing the waffles, repeat previous steps to bake more waffles.
16. When finished using the appliance, turn the browning control dial to the lowest setting and set the power switch to the OFF position. The power indicator and ready indicator lights will switch off. Disconnect the plug from the wall outlet.
17. Allow the appliance to cool down completely before moving, cleaning or storing.

CLEANING AND STORAGE

This appliance requires little maintenance. It contains no user-serviceable parts. Do not attempt to repair it yourself. Any servicing that requires disassembly, other than cleaning, must be performed by a qualified appliance repair technician.

TO CLEAN:

Be sure the waffle maker is unplugged and completely cool before cleaning. Wipe the exterior with a clean, damp cloth. Do not use abrasive cleaners or harsh chemicals. Do not submerge cord, plug, or appliance in water or other liquids. Clean the interior with a warm, soapy cloth. Rinse with a clean, damp cloth and dry thoroughly. Do not use abrasive cleaners or harsh chemicals. Do not use sharp or metal objects to clean as they may damage the non-stick or other surfaces. Clean appliance after every use.

TIP: Should any batter become baked onto the character icon plates, pour a small amount of cooking oil onto the batter. Allow it to soak for about 5 minutes so the batter will soften. Wipe away with a damp paper towel or soft cloth.

TO STORE:

Be sure all parts are clean and dry before storing. Store appliance in its box or in a clean, dry place. Never store it while it is hot. Never wrap cord tightly around the appliance; keep it loosely coiled.

WAFFLE BAKING HINTS AND SUGGESTIONS

- When preparing the waffle batter, do not over-mix it or the waffles will become tough and heavy. A few lumps in the batter are OK.
- Refrigerated batter may need some water or milk added to the mixture, as cold batter can thicken. Cold batter may also require a longer cooking time.
- Most waffle batter can be poured directly onto the nonstick waffle plates. Use a cooking spray for dessert waffles or any recipe with a lot of sugar. Dessert waffles will be more fragile and need extra care in removing them from the waffle maker. If your waffles start to stick, the waffle plates may need to be scrubbed with a nylon brush to remove any cooked-on food particles.
- For evenly shaped waffles, pour the batter into the center of each character icon reservoir and spread the batter to the edges. Use a heat-proof rubber spatula or the bottom of a non-metallic ladle or non-metallic spoon.
- Do not overfill. Use a pitcher or measuring cup to pour the batter rather than a ladle or spoon.
- Close the waffle maker lid immediately after removing a waffle to maintain the proper cooking temperature for additional waffles.
- Most waffles are done in approximately 3-6 minutes. Recipes made from scratch may take longer. Check if waffles are done after

about 5 minutes or once steam is no longer being emitted from the appliance. If the appliance does not open easily, allow waffles to cook for another minute before checking again.

- Baked waffles will accumulate steam between them and lose their crispness if stacked or cooled on a solid surface. For best results, move waffles to a wire cooling rack and do not stack.
- Finished waffles may be kept warm by placing them directly on the rack in a 200°F oven for up to 15 minutes.
- Waffles may also be warmed by placing them into the preheated waffle maker for 1 to 2 minutes.
- Baked waffles freeze well. Cool completely on wire rack. Store in plastic freezer bag or in an air-tight container, separating waffles with wax paper. Reheat frozen waffles until hot and crisp.

WAFFLE RECIPES

BUTTERMILK WAFFLES:

Ingredients:

- 2 cups all-purpose flour
- 1/2 teaspoon baking soda
- 1 teaspoon baking powder
- 1 teaspoon salt
- 1/4 cup sugar
- 3 eggs, beaten
- 2 tablespoons unsalted butter, melted
- 2 cups buttermilk

Directions:

1. Preheat waffle maker.
2. In a medium sized mixing bowl, whisk together flour, baking soda, baking powder, salt and sugar.
3. In a separate bowl, beat together eggs and melted butter. Add buttermilk.
4. Add wet ingredients to the dry ingredients and stir until combined.
5. Allow to sit for 4 to 5 minutes.
6. Using a measuring cup, carefully fill each character icon reservoir with waffle batter. See Operating Instructions for specific double flip waffle maker directions.
7. Bake between 3 to 6 minutes, using a toothpick to check that the waffle is thoroughly cooked.

CINNAMON WAFFLES:

Ingredients:

- 1 cup all-purpose flour
- 1/2 teaspoon baking soda
- 1 1/2 teaspoons baking powder
- 1/2 teaspoon salt
- 1 1/2 tablespoons sugar
- 1/4 to 1/2 teaspoon cinnamon
- 2 eggs, separated
- 4 tablespoons unsalted butter, melted
- 1 cup buttermilk
- 2 teaspoons vanilla extract

Directions

1. Preheat waffle maker.
2. Separate eggs' yolk from the egg whites. Set aside egg whites.
3. In a medium sized mixing bowl, whisk together egg yolks, vanilla, buttermilk, and butter until consistent.
4. In a separate bowl, mix together dry ingredients.
5. Add wet ingredients to the dry ingredients and stir until combined.
6. Whip egg whites until they just begin to peak. Fold into waffle mixture.
7. Using a measuring cup, carefully fill each character icon reservoir with waffle batter. See Operating Instructions for specific double flip waffle maker directions.
8. Bake between 3 to 5 minutes, using a toothpick to check that the waffle is thoroughly cooked.

CHOCOLATE WAFFLES

Ingredients:

- 1 cup all-purpose flour
- 1 teaspoon baking powder
- 1/2 teaspoon salt
- 1 cup sugar
- 1/2 cup unsweetened cocoa
- 2 eggs, lightly beaten
- 4 tablespoons unsalted butter, melted
- 1 cup buttermilk
- 2 teaspoons vanilla extract.

Directions:

1. Preheat waffle maker.
2. In a medium sized mixing bowl, combine flour, baking powder, salt, sugar and cocoa.
3. Add the eggs, buttermilk and vanilla. Whisk until consistent
4. Gradually add the melted butter, whisking until smooth.
5. Using a measuring cup, carefully fill each character icon reservoir with waffle batter. See Operating Instructions for specific double flip waffle maker directions.
6. Bake between 3 to 5 minutes, using a toothpick to check that the waffle is thoroughly cooked.

PUMPKIN WAFFLES:

Ingredients:

- 3 cups all-purpose flour
- 1/2 teaspoon baking soda
- 5 teaspoons baking powder
- 1/4 teaspoon salt
- 1/2 teaspoon cinnamon
- 1/2 teaspoon nutmeg
- 1/2 cup brown sugar, loosely packed
- 3 eggs, lightly beaten
- 12 tablespoons unsalted butter, melted
- 2 3/4 cup 2% milk
- 1 can (15 oz) 100% pure pumpkin

Directions:

1. Preheat waffle maker.
2. In large sized mixing bowl combine flour, baking soda, baking powder, salt, cinnamon and nutmeg.
3. In a separate bowl, mix the eggs and brown sugar. Add the pumpkin and milk and mix thoroughly. Gradually add the melted butter, mixing until smooth.
4. Add wet ingredients to the dry ingredients and stir just until dry ingredients are moist.
5. Using a measuring cup, carefully fill each character icon reservoir with waffle batter. See Operating Instructions for specific double flip waffle maker directions.
6. Bake between 3 and 5 minutes, using a toothpick to check that the waffle is thoroughly cooked.

STRAWBERRY YOGURT WAFFLES

Ingredients:

- 1 egg
- 1/2 cup strawberry yogurt
- 1 tablespoon canola oil
- 1/4 cup milk
- 1/2 cup flour
- 1/2 tablespoon sugar
- 1/2 teaspoon baking powder
- 1/4 teaspoon baking soda
- 1/4 teaspoon cinnamon
- 1/2 cup chopped fresh strawberries

Directions:

1. Preheat Waffle Maker.
2. Mix yogurt, egg sugar, oil and milk.
3. In a separate bowl, mix dry ingredients (not strawberries). Add to the wet mixture and stir in.
4. Gently fold in the strawberries.
5. Using a measuring cup, carefully fill each character icon reservoir with waffle batter. See Operating Instructions for specific flip waffle maker directions.
6. Bake between 3 and 5 minutes, using a toothpick to check that the waffle is thoroughly cooked.

ONE YEAR LIMITED WARRANTY

SELECT BRANDS, INC. warrants, subject to the conditions stated below, that from the date of purchase, this product will be free from mechanical defects for a period of one (1) year. SELECT BRANDS, INC., at its option, will repair or replace this product found to be defective during the warranty period. Should this product become defective by reason of improper workmanship or material defect during the specified warranty period, Select Brands, Inc. will repair or replace the same effecting all necessary parts replacements for a period of one year from the date of purchase.

Transportation charges on parts, or products in whole, submitted for repair or replacement, under this warranty, must be borne by the purchaser.

CONDITIONS: This warranty is valid for the original retail purchaser from the date of initial retail purchase and is not transferable. This warranty does not apply to product sold by third party resellers. Keep the original sales receipt. Proof of purchase is required to obtain warranty service or replacement. Dealers, service centers, or retail stores do not have the right to alter, modify or in any way, change the terms and conditions of this warranty.

Warranty registration is not necessary to obtain warranty on Select Brands, Inc. products. Save your proof of purchase receipt.

ABOUT YOUR PRODUCT WARRANTY: Most warranty repairs are handled routinely, but sometimes requests for warranty service may not be appropriate. For example, warranty service would NOT apply if the product damage occurred because of misuse, lack of routine maintenance, shipping, handling, warehousing or improper installation. Similarly, the warranty is void if the manufacturing date or the serial number on the product has been removed or the equipment has been altered or modified. During the warranty period, the authorized service dealer, at its option, will repair or replace any part that, upon examination, is found to be defective under normal use and service.

NORMAL WEAR: This warranty does not cover normal wear of parts or damage resulting from any of the following: Negligent use or misuse of the product; Improper voltage or current; Use contrary to the operation instructions; Deviation from instructions regarding storage and transportation; Repair or alteration by anyone other than SELECT BRANDS, INC. or an authorized service center. Further, the warranty does not cover Acts of God, such as fire, flood, hurricanes and tornadoes.

SELECT BRANDS, INC. shall not be liable for any incidental or consequential damages caused by the breach of any express or implied warranty. Except to the extent prohibited by applicable law, any implied warranty of merchantability or fitness for a particular purpose is limited in duration to the duration of the above warranty. Some states, provinces or jurisdictions do not allow the exclusion or limitation of incidental or consequential damages or limitations on how long an implied warranty lasts, so the above limitations or exclusion may not apply to you. This warranty gives you specific legal rights, and you may also have other rights that vary from state to state or province to province.

HOW TO OBTAIN WARRANTY SERVICE: You must contact SELECT BRANDS, INC. Customer Service at 1-913-663-4500. A Customer Service representative will attempt to resolve warranty issues over the phone. If telephone resolution is not possible, the Customer Service representative will require your assistance in performing routine diagnostic procedures. This warranty is effective for the time periods listed above and subject to the conditions provided for in this policy.